

All rights strictly reserved. Reproduction or issue to third parties in any form whatever is not permitted without written authority from the proprietor. Property of FCI. Copyright FCI.

Tous droits strictement reserves. Reproduction ou communication a des tiers interdite sous quelque forme que ce soit sans autorisation écrite du propriétaire. Propriete de c FCI. Droits de reproduction FCI.

PRODUCT NUMBER	DESCRIPTION
74872-****/***LF	UPPER ASSEMBLY FOR DOUBLE-DECK APPLICATION-61125 DRAWING FOR SINGLE- DECK

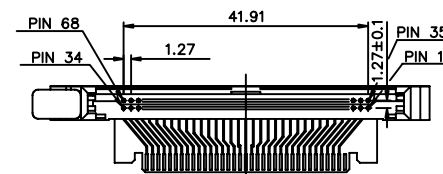
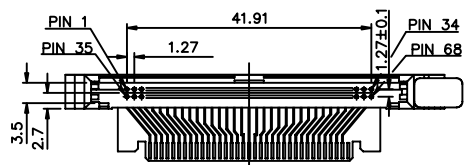
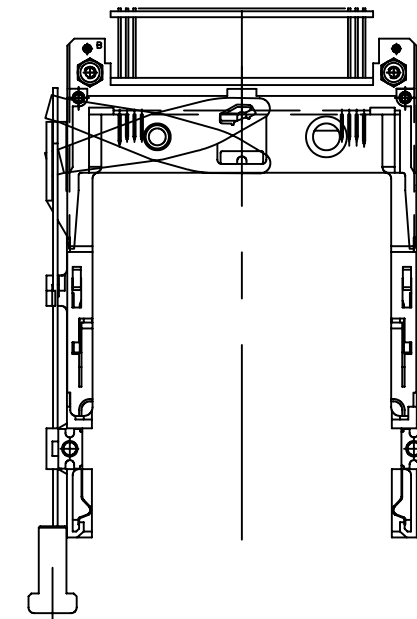
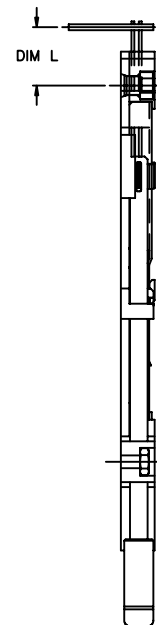
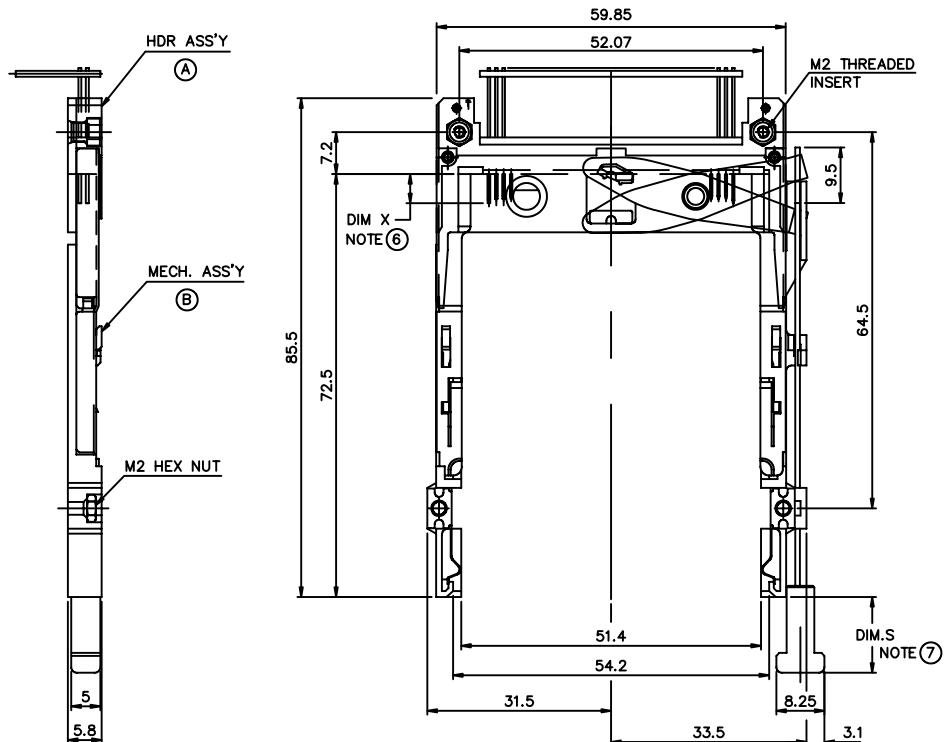

ABOVE P.C.B.
RIGHT PUSH-ROD
74872-0XXXX
74872-0XXXXLF

BELOW P.C.B.
RIGHT PUSH-ROD
74872-5XXXXLF

CONFIDENTIAL

mat'l. code				tolerances unless otherwise specified		CUSTOMER COPY	 Electronics www.fciconnect.com	
ltr	ecn no	dr	date	linear	.X±.3			projection
A	V80717	RHG	4/22/98		.XX±.13		3.3V EJECTOR HEADER ASS'Y	
B	V90963	CGC	4/26/99		.XXX±.051		68POS. SMT TYPE I II III	
C	V91050	CGC	5/15/99	angles	0° ±2'		product family PCMCIA	
D	V02245	RJR	10/30/00	dr	R.GRAPE 4/22/98		size dwg no	code
E	N05-0198	WB	07/05/05	enr	D.BRANN 4/22/98	1/1	74872	sheet
				chr	D.BRANN 4/22/98			1 of 5
				appd	D.BRANN 4/22/98			
sheet index	revision sheet	E	E	E	E	E		
		1	2	3	4	5		

All rights strictly reserved. Reproduction or issue to third parties in any form whatever is not permitted without written authority from the proprietor. Property of FCI. Copyright FCI.

Tous droits strictement réservés. Reproduction ou communication a des tiers interdite sous quelque forme que ce soit sans autorisation écrite du propriétaire. Propriete de c FCI. Droits de reproduction FCI.



PRODUCT NUMBER	DESCRIPTION
74872-****/***LF	UPPER ASSEMBLY FOR DOUBLE-DECK APPLICATION-61125 DRAWING FOR SINGLE- DECK

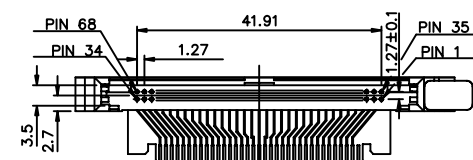
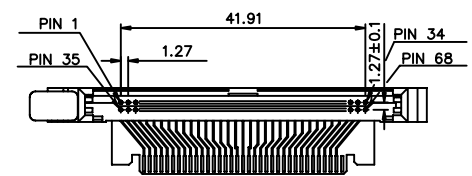
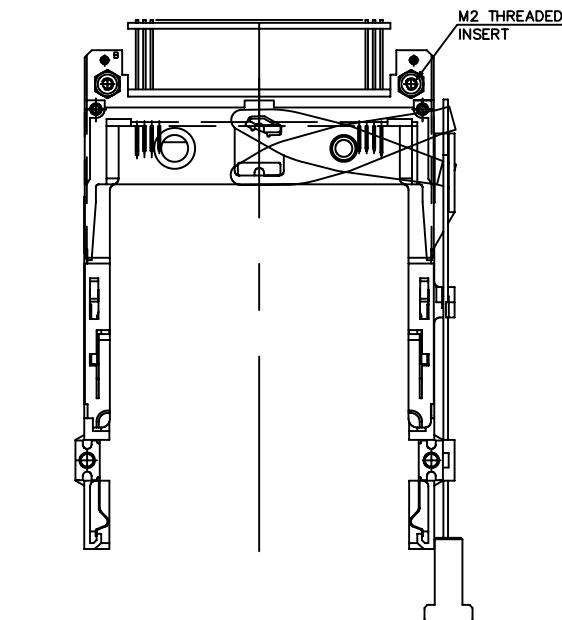
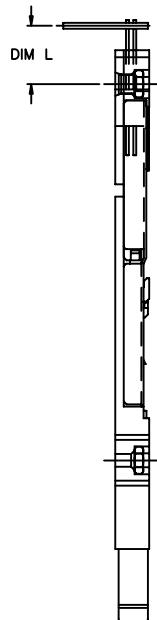
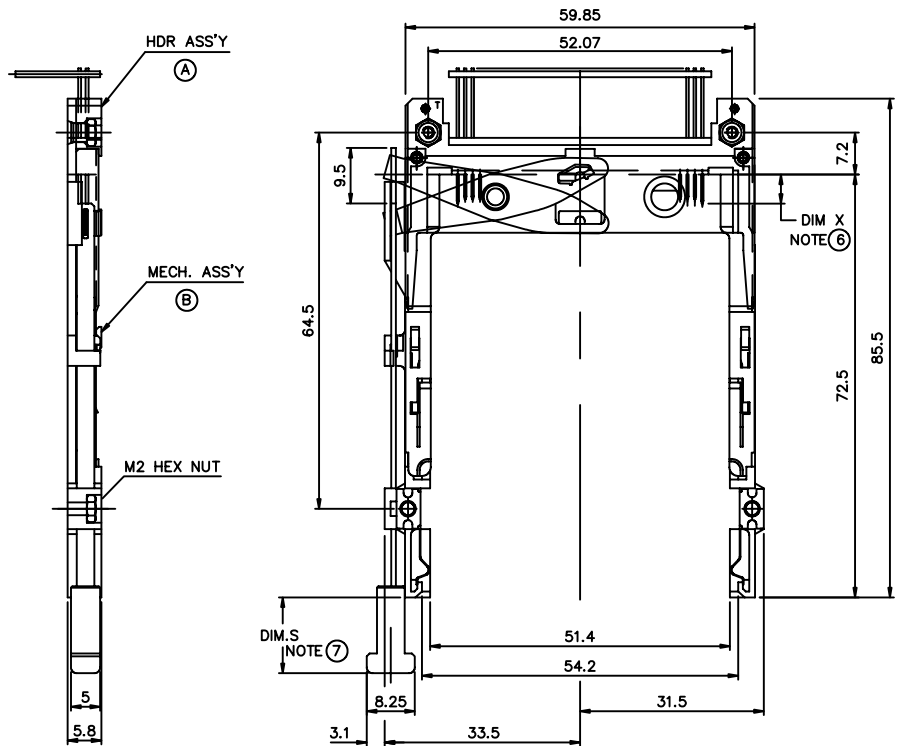

ABOVE P.C.B.
LEFT PUSH-ROD
74872-1XXXX
74872-1XXXXLF

BELOW P.C.B.
LEFT PUSH-ROD
74872-6XXXX
74872-6XXXXLF

CONFIDENTIAL

mat'l. code				tolerances unless otherwise specified		CUSTOMER COPY	 Electronics www.fciconnect.com
ltr	ecn no	dr	date	linear	.X±.3		
E					.XX±.13		3.3V EJECTOR HEADER ASS'Y
				angles	.XXX±.051		68 POS. SMT I II III
				dr	R.GRAPE 4/22/98	 MM	product family PCMCIA
				enr	D.BRANN 4/22/98		code
				chr	D.BRANN 4/22/98	scale	size dwg no
				appd	D.BRANN 4/22/98	1/1	A4 74872
sheet index	revision sheet						sheet 2 of

PRODUCT NUMBER
74872-****

BELOW	LEFT	74872-655**	55977-5550	95627-00**	6.55
		74872-645**	55977-5543	95627-00**	6.55
		74872-625**	55977-5522	95627-00**	9.0
		74872-605**	55977-5500	95627-00**	10.0
BELOW	RIGHT	74872-555**	55977-5550	95627-10**	6.55
		74872-545**	55977-5543	95627-10**	6.55
		74872-525**	55977-5522	95627-10**	9.0
		74872-505**	55977-5500	95627-10**	10.0
ABOVE	LEFT	74872-155**	55977-0550	95627-10**	6.55
		74872-145**	55977-0543	95627-10**	6.55
		74872-125**	55977-0522	95627-10**	9.0
	RIGHT	74872-105**	55977-0500	95627-10**	10.0
		74872-250CA (10)	55977-0150	95627-05CA	-0.3
		74872-055**	55977-0550	95627-00**	6.55
		74872-045**	55977-0543	95627-00**	6.55
		74872-025**	55977-0522	95627-00**	9.0
74872-005**	55977-0500	95627-00**	10.0		

P.C.B. SIDE (3)	PUSH ROD LOCATION (3)	PRODUCT NO.	HDR & PWB ASS'Y (A) NOTE (9)	EJ ASS'Y (B)	DIM L
-----------------	-----------------------	-------------	------------------------------	--------------	-------

** : SEE NOTE (7) TABLE J

NOTES:

1. 8mm MIN. CARD EJECT.
2. EJECT TRAVEL: 9.5mm
- (3) PUSH ROD LOCATION AND P.C.B. SIDE ARE AS APPEARS INSTALLED.
4. MATERIAL
 - 4.1 PART (A) (HEADER ASS'Y)
 - PLASTIC : HOUSING ...LCP UL94V-0
 - PIN : PHOSPHOR BRONZE
 - PCB : FR4
 - 4.2 PART (B) (EJECT MECHANISM ASS'Y)
 - PLASTIC : GUIDE: POLYPHTHARAMID UL94V-0 BLACK
 - : PUSH ROD CAP: POLYPHTHARAMID UL94V-0 BLACK
 - PLATE AND PUSH ROD : STAINLESS
 - EMI CONTACT: PHOSPHOR BRONZE
5. FINISH (PIN)
 - UNDER PLATING : 0.5 μm Ni
 - CONTACT AREA : 0.1 μm GOLD OVER 0.5μm Pd-Ni (EXCEPT-250CA)
 - SOLDER TAIL : 2.5 μm Sn-Pb

(6) DIM "X"

4.25±0.1	3.5±0.1	5.0±0.1
OTHERS	36,67	1,17,34,35,51,68

(7) TABLE J - PUSH ROD BUTTON LENGTH

**	DIM.S
CA	13.0
DA	15.6

8. RECOMMENDED SCREW TORQUE 1.0 TO 1.5 MAX in-lbs (1.2-1.7 cm-kgs).
- (9) THREADED INSERTS ARE INSTALLED IN HEADER 55977.
- (10) 74872-250CA HAS 5mm STAND-OFFS AND CONTACT AREA PLATING 0.1μm GOLD OVER 0.8μm Pd-Ni - PAGE 4
11. RECOMMENDED MATING CONNECTOR P/N 91931-31169.
12. RECOMMENDED PCB LAYOUTS-TA1056

CONFIDENTIAL

mat'l. code				tolerances unless otherwise specified		CUSTOMER COPY	Electronics FCI www.fciconnect.com						
ltr	ecn no	dr	date	linear	.X±.3	projection	title	3.3V EJECTOR HEADER ASS'Y 68POS. SMT TYPE I II III					
E					.XX±.13				MM	product family PCMCIA	code -		
					.XXX±.051							scale	size dwg no
				angles	0° ±2'	A4	74872						
				dr	R.GRAPE 4/22/98			1/1					
				enr	D.BRANN 4/22/98								
				chr	D.BRANN 4/22/98								
				appd	D.BRANN 4/22/98								
sheet index	revision sheet												

Tous droits strictement reserves. Reproduction ou communication a des tiers interdite sous quelque forme que ce soit sans autorisation écrite du propriétaire. Propriete de c FCI. Droits de reproduction FCI.

All rights strictly reserved. Reproduction or issue to third parties in any form whatever is not permitted without written authority from the proprietor. Property of FCI. Copyright FCI.

PRODUCT NUMBER
74872-****/****LF

BELOW	LEFT	74872-655**LF	55977-5550LF	95627-00**	6.55
		74872-645**LF	55977-5543LF	95627-00**	6.55
		74872-625**LF	55977-5522LF	95627-00**	9.0
		74872-605**LF	55977-5500LF	95627-00**	10.0
BELOW	RIGHT	74872-555**LF	55977-5550LF	95627-10**	6.55
		74872-545**LF	55977-5543LF	95627-10**	6.55
		74872-525**LF	55977-5522LF	95627-10**	9.0
		74872-505**LF	55977-5500LF	95627-10**	10.0
ABOVE	LEFT	74872-155**LF	55977-0550LF	95627-10**	6.55
		74872-145**LF	55977-0543LF	95627-10**	6.55
		74872-125**LF	55977-0522LF	95627-10**	9.0
	RIGHT	74872-105**LF	55977-0500LF	95627-10**	10.0
		74872-250CALF ^⑩	55977-0150LF	95627-05CA	-0.3
		74872-055**LF	55977-0550LF	95627-00**	6.55
		74872-045**LF	55977-0543LF	95627-00**	6.55
		74872-025**LF	55977-0522LF	95627-00**	9.0
74872-005**LF	55977-0500LF	95627-00**	10.0		

P.C.B. SIDE ^③	PUSH ROD LOCATION ^④	PRODUCT NO.	HDR & PWB ASS'Y ^⑤ ^⑥ NOTE ^⑨	EJ ASS'Y ^⑦	DIM L
--------------------------	--------------------------------	-------------	---	-----------------------	-------

** : SEE NOTE ^⑦ TABLE J

NOTES:

- 8mm MIN. CARD EJECT.
- EJECT TRAVEL: 9.5mm
- ^③ PUSH ROD LOCATION AND P.C.B. SIDE ARE AS APPEARS INSTALLED.
- MATERIAL
 - PART [Ⓐ] (HEADER ASS'Y)
PLASTIC : HOUSING ...LCP UL94V-0
PIN : PHOSPHOR BRONZE
PCB : FR4
 - PART [Ⓑ] (EJECT MECHANISM ASS'Y)
PLASTIC : GUIDE: POLYPHTHARAMID UL94V-0 BLACK
: PUSH ROD CAP: POLYPHTHARAMID UL94V-0 BLACK
PLATE AND PUSH ROD : STAINLESS
EMI CONTACT: PHOSPHOR BRONZE
- FINISH (PIN)
UNDER PLATING : 1.27µm Ni
CONTACT AREA : 0.1µm GOLD OVER 0.5µm Pd-Ni (EXCEPT-250CA)
SOLDER TAIL : 2.5µm PURE Sn

^⑥ DIM "X"

4.25±0.1	3.5±0.1	5.0±0.1
OTHERS	36,67	1,17,34,35,51,68

^⑦ TABLE J - PUSH ROD BUTTON LENGTH

**	DIM.S
CA	13.0
DA	15.6

- RECOMMENDED SCREW TORQUE 1.0 TO 1.5 MAX in-lbs (1.2-1.7 cm-kgs).
- THREADED INSERTS ARE INSTALLED IN HEADER 55977.
- 74872-250CA HAS 5mm STAND-OFFS AND CONTACT AREA PLATING 0.1µm GOLD OVER 0.8µm Pd-Ni - PAGE 4
- RECOMMENDED MATING CONNECTOR P/N 91931-31169 OR 91931-31169LF .
- RECOMMENDED PCB LAYOUTS-TA1056
- IF LEAD FREE P.N.THE HOUSING WILL WITHSTAND EXPOSURE TO 260°C PEAK TEMPERATURE FOR 10 SECONDS IN A WAVE SOLDER APPLICATION WITH A 1.00MM MINIMUM THICK CIRCUIT BOARD.
- IF LEAD FREE P/N.THE PRODUCT MEETS EUROPEAN UNION DIRECTIVES AND OTHER COUNTRY REGULATIONS AS DESCRIBED IN GS-22-008
- LEAD FREE P/N PACKAGING MEETS GS-14-920 SPECIFICATION

CONFIDENTIAL

mat'l. code				tolerances unless otherwise specified		CUSTOMER COPY	Electronics FCI www.fciconnect.com		
ltr	ecn no	dr	date	linear	.X±.3	projection	title		
E					.XX±.13			3.3V EJECTOR HEADER ASS'Y	
					.XXX±.051			68POS. SMT TYPE I II III	
				angles	0° ±2'		product family PCMCIA		
				dr	R.GRAPE 4/22/98		size		
				enr	D.BRANN 4/22/98		dwg no		
				chr	D.BRANN 4/22/98		74872		
				appd	D.BRANN 4/22/98		sheet 4 of		
sheet index	revision sheet					scale	1/1	A4	

Tous droits strictement reserves. Reproduction ou communication a des tiers interdite sous quelque forme que ce soit sans autorisation écrite du propriétaire. Propriete de c FCI. Droits de reproduction FCI.

All rights strictly reserved. Reproduction or issue to third parties in any form whatever is not permitted without written authority from the proprietor. Property of FCI. Copyright FCI.

All rights strictly reserved. Reproduction or issue to third parties in any form whatever is not permitted without written authority from the proprietor. Property of FCI. Copyright FCI.



Tous droits strictement réservés. Reproduction ou communication à des tiers interdite sous quelque forme que ce soit sans autorisation écrite du propriétaire. Propriété de c FCI. Droits de reproduction FCI.

PRODUCT NO.
74872-250CA
74872-250CALF

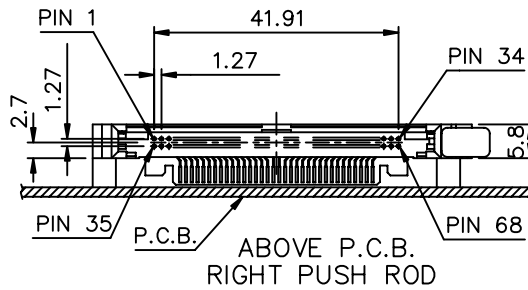
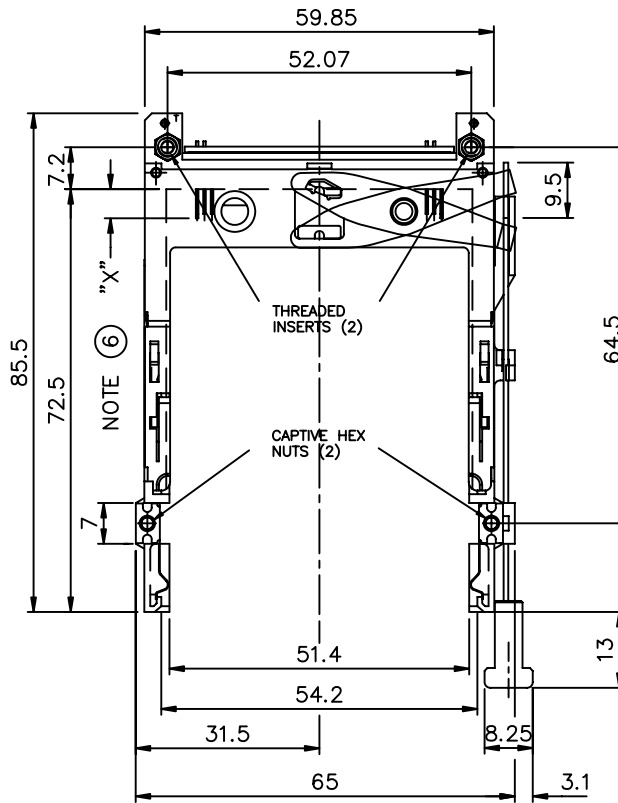
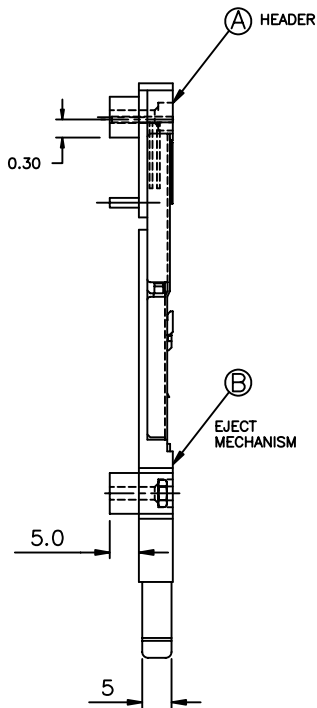

74872-250CA/250CALF

mat'l. code				tolerances unless otherwise specified			CUSTOMER COPY		 Electronics www.fciconnect.com	
ltr	ecn no	dr	date	linear	.XX±.3		projection	title		
E					.XXX±.051			3.3V EJECTOR HEADER ASS'Y		
					0° ±2'			68POS. SMT TYPE I II III		
				angles	dr	R. GRAPE	4/22/98	product family		code
					enr	D. BRANN	4/22/98	PCMCIA		
					chr	D. BRANN	4/22/98	size		dwg no
					appd	D. BRANN	4/22/98	A4		74872
sheet index	revision sheet							scale	1:1	sheet 5 of